

ACCX-TAP-DC100-E

7 Pin AC/DC Streetlight Power Tap

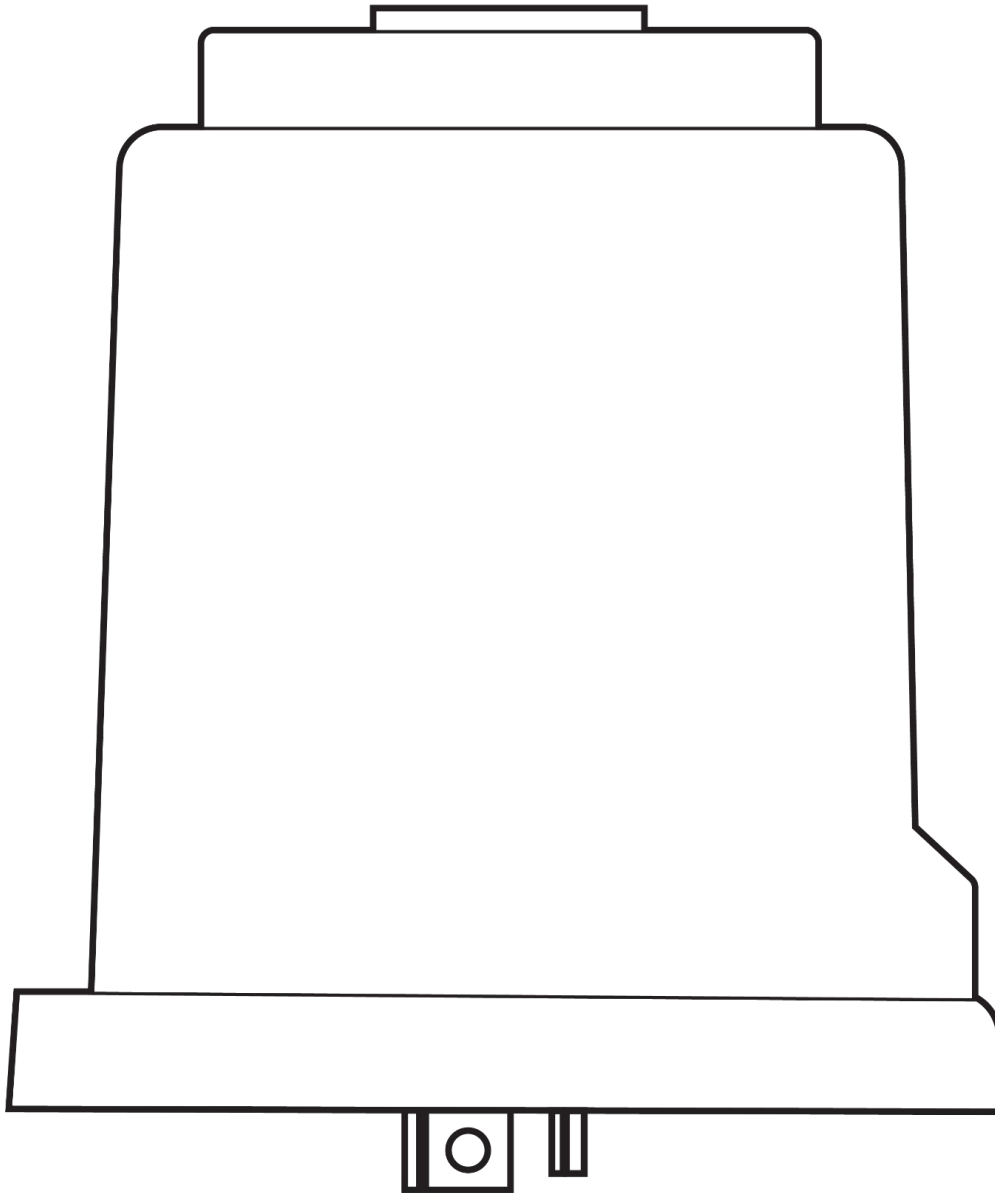

Document

Document Details

Version

V1.0 (20240408)

(V1.0 published 20240408)

Firmware

Firmware version can be verified on Verkada

Command `command.verkada.com`.

Product Models

This install guide pertains to model ACCX-TAP-DC100-E

Support

Thank you for purchasing this Verkada product. If for any reason you're experiencing issues or need assistance, please contact our 24/7 Technical Support Team immediately.

Sincerely,

The Verkada Team

verkada.com/support

© Copyright 2023 Verkada Inc. All rights reserved.

Verkada and the Verkada logo are registered trademarks or service marks of Verkada Inc. ("Verkada"). All other trademarks are the property of their respective owners.

Verkada may make changes to this document at any time without notice. The information presented herein may be inaccurate or outdated, and Verkada is under no obligation to maintain it. ALL INFORMATION IS PROVIDED "AS-IS" AND WITHOUT ANY WARRANTIES, IMPLIED, EXPRESS, OR OTHERWISE. VERKADA DISCLAIMS LIABILITY FOR ALL DAMAGES, INCLUDING WITHOUT LIMITATION ANY DIRECT, INDIRECT, SPECIAL, INCIDENTAL, PUNITIVE, OR CONSEQUENTIAL DAMAGES, ARISING OUT OF USE OF THIS DOCUMENT.

Any intellectual property rights relating to Verkada products are and shall remain Verkada's exclusive property. Use of any Verkada product is subject to Verkada's end user agreement or other executed agreement with Verkada. No license, either expressed or implied, to use or distribute any Verkada product is granted under this document.

This document may not be sold, resold, licensed or sublicensed and may not be transferred without Verkada's prior written consent. No part of this document may be reproduced in whole or in part without the express written consent of Verkada.



Installation

Mounting

If present, disconnect the photocontrol installed on the streetlight by twisting and lifting upwards.

Install the Power Tap by plugging it into the receptacle and twisting to lock it in place.

Reinstall the photocontrol by plugging it into the top of the Power Tap and twisting to lock.

Connect the ethernet cable providing power from the Power Tap to your Verkada gateway.

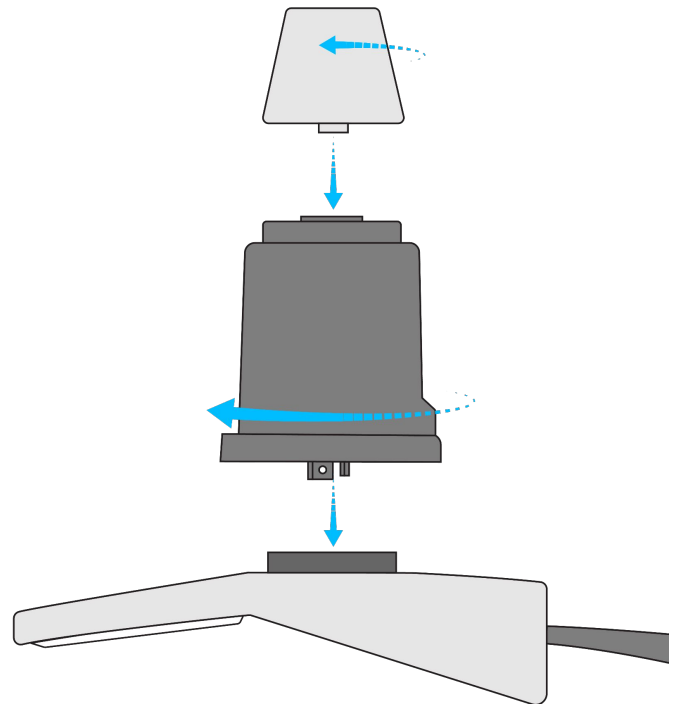
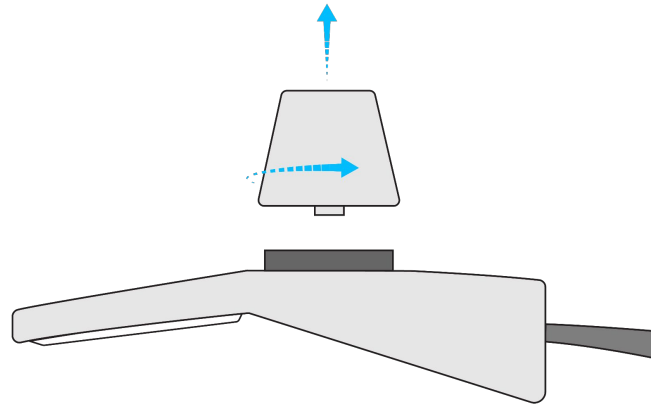

Appendix

Support

Thank you for purchasing this Verkada product. If for any reason you're experiencing issues or need assistance, please contact our 24/7 Technical Support Team immediately.

Sincerely,
The Verkada Team
verkada.com/support

